



## Tough Steel Sprocket Segments

### Improved wear life sprocket segments

Caterpillar offers Tough Steel sprocket segments that provide significant wear life improvements over standard steel segments. Tough Steel sprocket segments:

- Utilize a Caterpillar® patented, wear-resistant material
- Increase sprocket wear life and improve track bushing wear life
- Provide improved bolt retention

Field tests indicate sprocket wear life can increase by as much as 50 percent. Tough Steel segments also improve bushing life by maintaining the proper relationship between the sprocket and bushing contact area, reducing the amount of sliding that occurs as the bushing engages the sprocket.



## Cat® Track System Availability

Machine Type	Track System			
	SystemOne™	Heavy Duty	Enhanced! SALT	Classic
953B/C	•		•	
953D	•			
D4H/D5M/D5N	•	•		
D5H/D6M/D6N	•	•	•	
D6D			•	•
963B/C	•		•	
963D	•			
D6H/R	•	•	•	
D6T	•	•		
D7G			•	•
973			•	
D7H/R		•	•	



**A Complete Guide to Caterpillar® Undercarriage Systems**  
**How to select the best track system for Medium Size Track-Type Tractors and Loaders.**



**Customers**  
 For more information, contact your local dealer or log on to [www.cat.com](http://www.cat.com).  
**Dealers**  
 For more information, visit your internal Caterpillar undercarriage Web site.

© 2008 Caterpillar. All Rights Reserved. CAT, CATERPILLAR, their respective logos, Classic, SystemOne, "Caterpillar Yellow" and the POWER EDGE trade dress, as well as corporate and product identity used herein, are trademarks of Caterpillar and may not be used without permission.

Printed in the USA. PEDJ0081

**CATERPILLAR®**  
 TODAY'S WORK. TOMORROW'S WORLD.™

**CATERPILLAR®**



## Driving the industry in undercarriage innovation

Since the first track-type tractor was introduced over a century ago, Caterpillar has been behind virtually every major undercarriage improvement and innovation. As industry leaders, we realized early on that our success depended on our customers' success; that finding new ways to lower owning and operating costs meant a better return on their investment. The ability to offer a dependable undercarriage system with the lowest cost-per-hour for virtually every type of customer continues to be what drives us today.

### An undercarriage for every application

Delivering systems with the longest life means correctly matching the undercarriage configuration to underfoot demands. Caterpillar offers a wide variety of tracks and shoes to fit the complete range of abrasion and impact levels and all underfoot conditions. To ensure maximum performance from your track-type tractor, this guide is designed to help you select the correct track system for your specific needs and applications. The result? The highest performance at the lowest cost-per-hour.

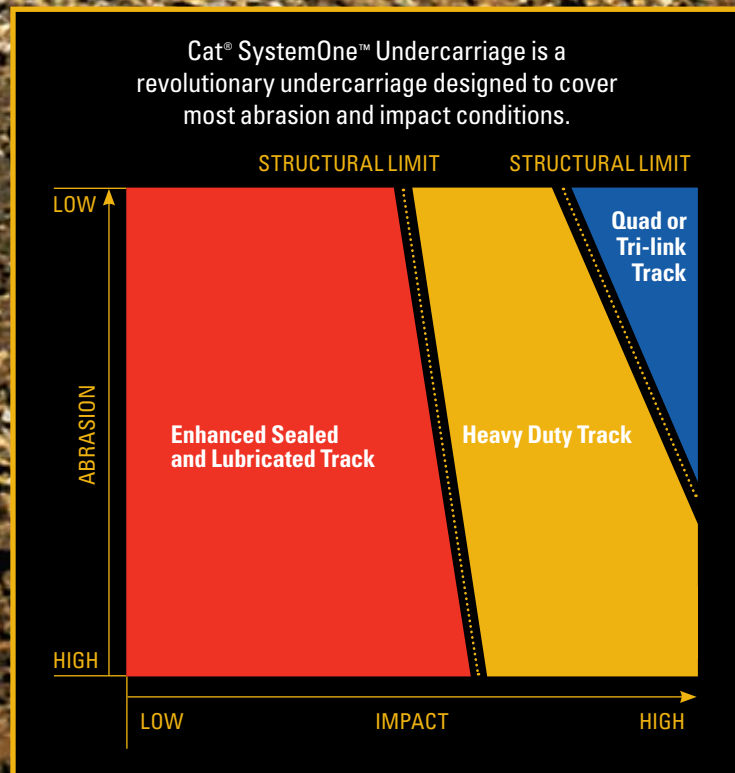

### Enhanced Sealed and Lubricated Track

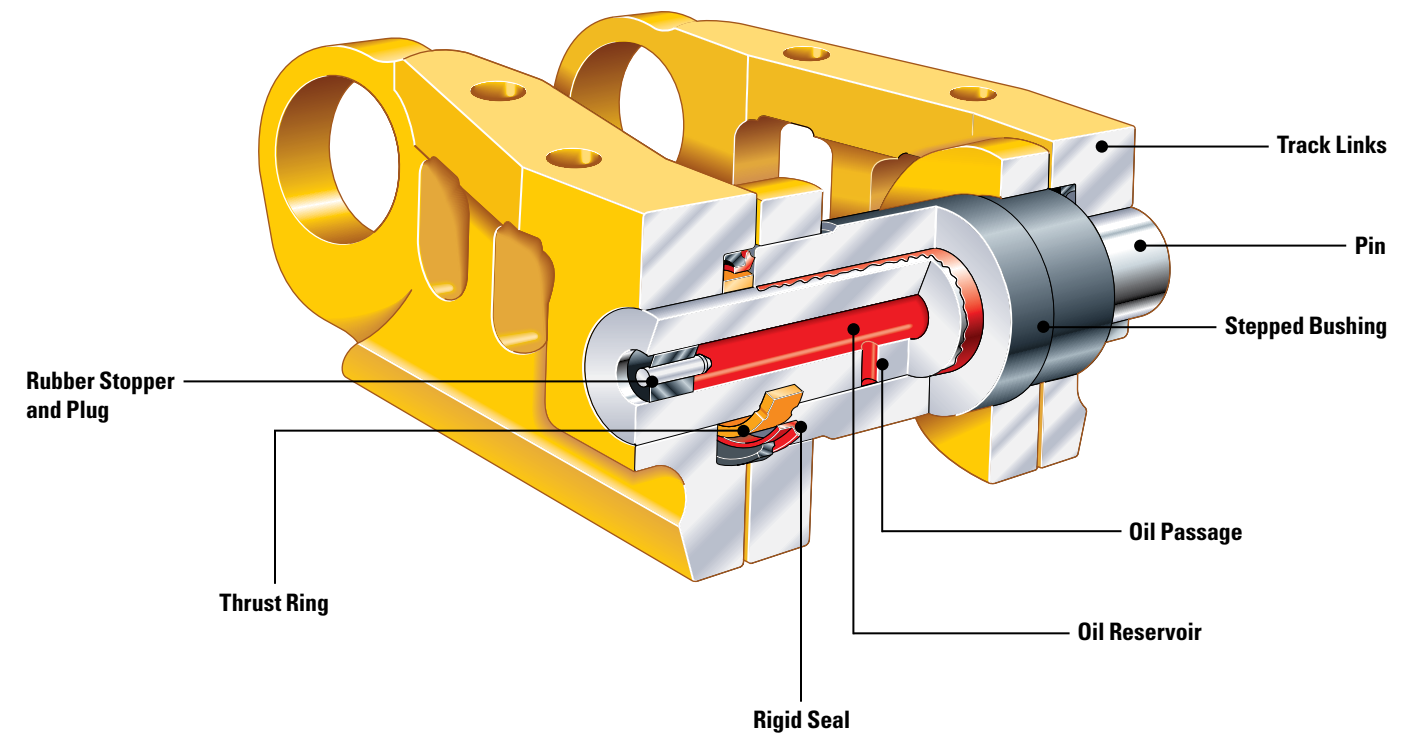

#### Track Links

Track links have high core hardness, helping to hold the track section together.

#### Pin

Cross-drilled pins provide an oil passage between the pin and the bushing.

#### Oil Reservoirs

Carefully machined oil reservoirs ensure proper oil distribution.

#### Stepped Bushings

Stepped bushings, which are thicker in the middle, provide more external wear material.

#### Rigid Seal

Rigid seal provides better sealability, reducing the effect of impact on track joints.

### Enhanced Sealed and Lubricated Track – a hybrid of field-proven innovation.

The enhanced Sealed and Lubricated Track (SALT) represents the best of all worlds, a hybrid of high performance features from previous Track-Type Tractor (TTT) and Track-Type Loader (TTL) undercarriage technology. For instance, enhanced Sealed and Lubricated Track incorporates:

- Increased link roller system life of the tall link from the TTL.
- Robust pin retention and superior bushing retention design from the elevated TTT.
- Enhanced spalling resistance geometry from the Oval TTT.

The result is a longer wearing system compared to the Sealed Track, one that is specifically designed to seal in lubricants and keep out debris. Today's enhanced Sealed and Lubricated Track offers extended system life and greatly reduced operating costs. When you see how each component is designed, you'll understand how enhanced Sealed and Lubricated Track can cut owning and operating costs – and make a real difference on the bottom line.

### Custom Track Service

To ensure you get the absolute most from your machine, Caterpillar offers Custom Track Service (CTS), a comprehensive service to help manage undercarriage systems. Our parts and service representatives will perform inspections to project remaining wear life, in order to schedule maintenance. Equipped with the advanced tools and necessary parts to perform cost-efficient, accurate track work, CTS minimizes downtime and gets machines back to work quickly.

### Cat SystemOne Undercarriage

- Works in most all applications
- Ideal for a wide variety of applications and environments including: logging, stumping, clearing, road building, side sloping, fine grading, quarries, mines, sand, gumbo and more

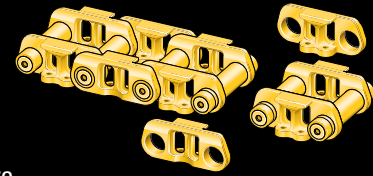

### Cat® SystemOne™ Undercarriage

The Cat® SystemOne™ Undercarriage is a revolutionary design, virtually redesigned from the ground up. Designed to work and to wear as a system, SystemOne Undercarriage offers balanced wear life. Its innovative rotating bushing design increases bushing life and eliminates the need for a bushing turn – or for any maintenance between track changes. The SystemOne design also eliminates link scalloping and the rough ride that results, ensuring users a better, more comfortable ride.

Proven in the field, SystemOne can dramatically lower owning and operating costs from 35 percent to 70 percent. And, in many cases, users report double the life – or more.

### Enhanced Sealed and Lubricated Track

- Works best in low- to moderate- impact conditions and abrasion areas
- Ideal for a wide range of underfoot conditions

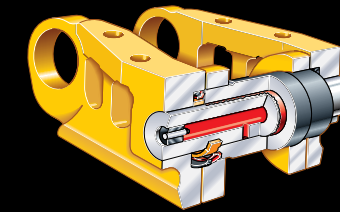

### Enhanced Sealed and Lubricated Track

A universal track option with a longer wear life, the Sealed and Lubricated Track is loaded with features to lower owning and operating costs compared to the Sealed Undercarriage. By design, it eliminates or significantly reduces pin and bushing wear, and eliminates both track stretch and snakiness. These innovations allow for a reduction in maintenance costs and downtime, extended bushing and sprocket life and better idler rebuildability for a longer service life.

To maximize system life and reduce maintenance costs further, a wet bushing turn can be performed, offering wear life on the second side equal to the first, provided the track is operated in similar conditions.

### Heavy Duty Sealed and Lubricated Track

- Works best in moderate- to high-impact conditions
- Ideal for logging/reforestation, side-sloping work, rocky conditions and any uneven terrain

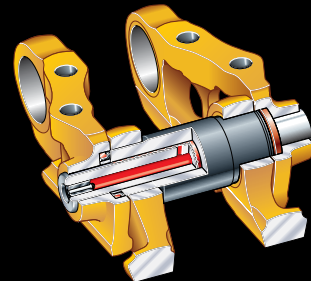

### Heavy Duty Sealed and Lubricated Track

The Heavy Duty Track is built to offset the effects of high-impact loads and stresses, featuring redesigned links, pins and bushings for enhanced strength, durability and retention. In most underfoot conditions, the Heavy Duty Track can extend undercarriage system life, with the greatest benefits possible in aggressive, high-impact applications.

Other enhancements include improved track joint retention and sealability and stronger components that resist cracking and breakage. By extending system wear life, the Heavy Duty Track lowers owning and operating costs in the most extreme conditions compared to Sealed and Lubricated Track.

### Cat Classic Parts

- Complete undercarriage for select models
- Ideal for machines out of production 10 years or more



### Cat® Classic™ Parts

Cat® Classic™ Parts offer owners of older Cat® equipment a value-priced repair alternative, along with the confidence that comes with the Cat name. Designed to complement original, Cat Reman, dealer exchange and used parts, Classic Parts help manage owning and operating costs of aging equipment, keeping in mind the desire to avoid costly repairs.

Cat Classic Parts offer complete undercarriage solutions for over 30 different, older Cat track-type tractors, with new models being added. Cat Classic undercarriage parts include affordable link assemblies, track shoes, hardware, pin and bushing groups, rollers, idlers, sprocket segment groups, guards and recoil mechanism parts – all manufactured with the same quality standards and backed by the standard parts warranty.

### Quad-and Tri-link Track\*

Additional outrigger chains improve undercarriage strength, distribute peak loads more evenly, reduce dry joints and improve reliability. The result is longer track life and reduced costs.

#### Quad-and Tri-link Track:

- Works best in the most severe, high-impact conditions
- Ideal for logging (skidding), stumping, work in rocky terrains, or any application where shoe deflection is high

\*Only available with the Heavy Duty Track Option

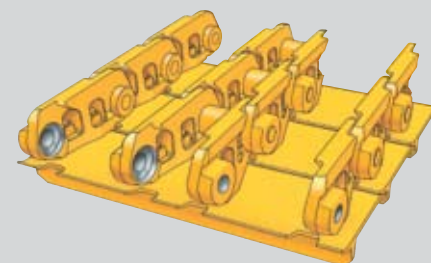

## Track Shoe Options

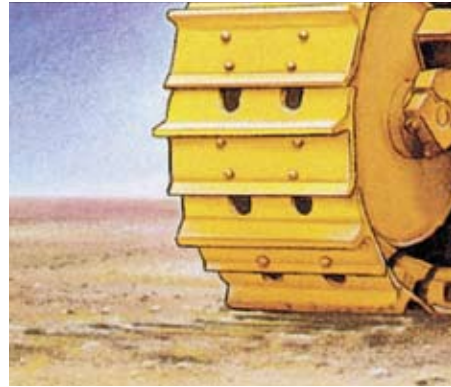

### Moderate Service Shoes (Single-Grouser Shoes)

- Work best in low- to medium-abrasion conditions and low- to moderate-impact conditions
- All-purpose shoes recommended for any general application
- Provide good penetration and traction while resisting wear and bending



### Center Hole Shoes (Moderate and Extreme Service Shoes)

- Work best in applications where packing causes the track to tighten, accelerating pin and bushing wear
- Recommended for applications where large amounts of debris tend to pack in the track
- Reduce extrudable packing between the shoe and the bushing due to sprockets that punch out dirt and debris
- Also available for Double-Grouser and Chopper Shoes

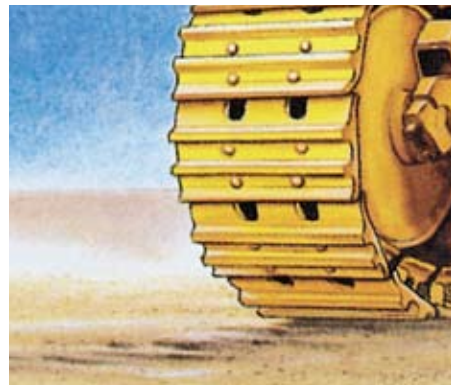

### Multi-Grouser Shoes

- Work best in applications that require less penetration and traction
- Recommended for applications that require better turning capability and less ground disturbance
- Feature two or three short grousers instead of one tall grouser, low usage on medium-size track-type tractors



### Extreme Service Shoes (Single-Grouser Shoes)

- Work best in moderate- to high-impact conditions
- Recommended for applications where the links outlast the shoes
- Have more hardened wear material than moderate service shoes



### Self-Cleaning, Low Ground Pressure Shoes

- Work best in soft underfoot conditions; should not be used in highly abrasive or high-impact conditions
- Recommended for applications where flotation is a problem (LGP only)
- Separate from one another as they move around the sprocket and idler, allowing dirt and debris to fall out

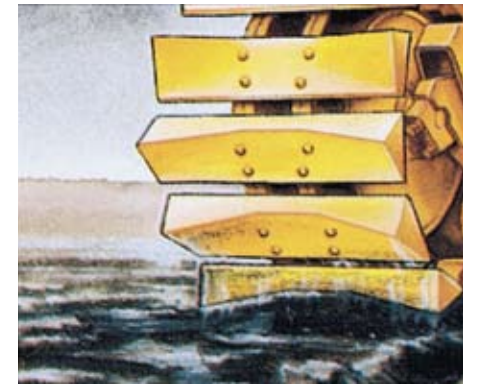

### Chopper Shoes

- Work best in applications where debris tends to stick in the shoes
- Recommended for landfills, transfer stations and demolition applications
- Feature a full-length grouser to resist bending, diagonal side grousers for increased chopping ability and a large trapezoidal center hole for increased material extrusion

